

Centralni privod vzduchu Ø 125mm
 Zentralluftzufuhr Ø 125mm
 Central air inlet Ø 125mm

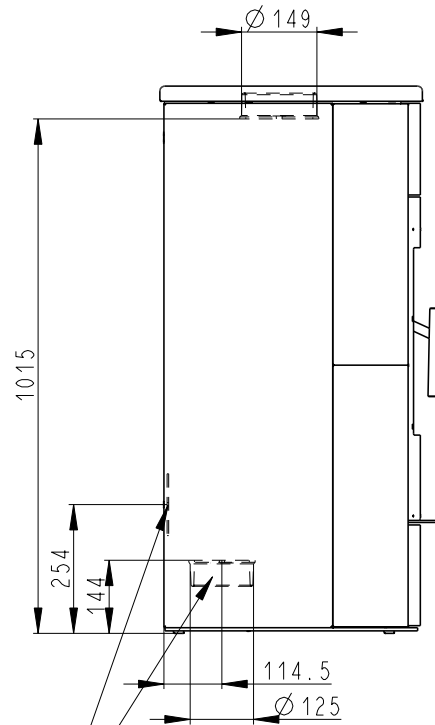

Jimka G 1/2" (160 mm)
 Tauchhülse G 1/2" (160 mm)
 Reservoir G 1/2" (160 mm)

Jimka G 1/2" (65 mm)
 Tauchhülse G 1/2" (65 mm)
 Reservoir G 1/2" (65 mm)

Odvzdušnovací ventil G 1/2"
 Entlüftungsventil G 1/2"
 Air-escape valve G 1/2"

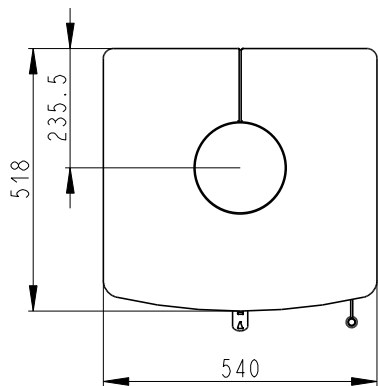

SEKUNDARNI VZDUCH
 Sekundärluft
 Secondary air
 A/UND/AND
 PRIMARNI VZDUCH
 Primärluft
 Primary air

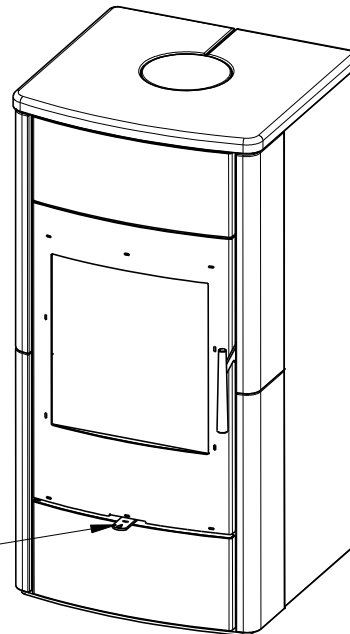

Vstup do vychlazovaci smycky 1/2" vnitřni
 Zulauf der thermischen Ablaufsicherung 1/2"- Innen
 Cooling loop input 1/2"- inside

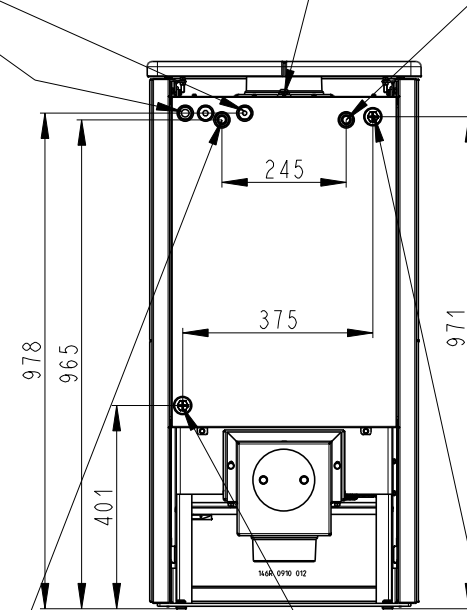

Vstup do vymeniku G3/4"- vnitřni
 Rücklauf G3/4"- Innen
 Water exchanger input G3/4"- inside

Vystup z vymeniku G3/4"- vnitřni
 Zulauf G3/4"- Innen
 Water exchanger output G3/4"- inside

Vystup z vychlazovaci smycky 1/2" vnitřni
 Rücklauf der thermischen Ablaufsicherung 1/2"- Innen
 Cooling loop output 1/2"- inside